

European Technical Assessment

ETA-08/0035 of 2024-12-23

General Part

Technical Assessment Body issuing the European Technical Assessment	SINTEF AS by its institute SINTEF Community
Trade name of the construction product	HRC100 Series T-headed bars HRC200 Series T-headed bars
Product family to which the construction product belongs	Headed reinforcing steel bars
Manufacturer	HRC Europe Lierstranda 107 NO-3412 Lierstranda Norway
Manufacturing plant(s)	HRC Europe manufacturing plants
This European Technical Assessment contains	10 pages including 3 Annexes which form an integral part of this assessment
This European Technical Assessment is issued in accordance with Regulation (EU) No 305/2011, on the basis of	EAD 160012-01-0301 Headed reinforcing steel bars
This version replaces	ETA-08/0035, issued on 2023-06-02

Translations of this European Technical Assessment in other languages shall fully correspond to the original issued document and should be identified as such.

Communication of this European Technical Assessment, including transmission by electronic means, shall be in full (excepted the confidential Annex(es) referred to above). However, partial reproduction may be made, with the written consent of the issuing Technical Assessment Body. Any partial reproduction has to be identified as such.

Contents

1. Technical description of the product	3
2. Specification of the intended use(s) in accordance with the applicable European Assessment Document (hereinafter EAD)	3
3. Performance of the product and references to the methods used for its assessment	4
3.1 Basic Works Requirement 1 (BWR 1) – Mechanical resistance and stability	4
3.2 Basic Works Requirement 2 (BWR 2) – Safety in case of fire	4
4. Assessment and verification of constancy of performance (hereinafter AVCP) system applied, with reference to its legal base	4
5. Technical details necessary for the implementation of the AVCP system, as provided for in the applicable EAD	4
ANNEX A – PRODUCT DESCRIPTION	5
A.1 Dimensions – HRC100 Series	5
A.2 Dimensions – HRC200 Series	6
A.3 Materials – HRC100 and 200 Series.....	6
ANNEX B – INTENDED USE	7
B.1 Specification of intended use	7
B.2 Concrete	7
B.3 Design	7
B.4 Installation.....	7
ANNEX C – PRODUCT PERFORMANCE	8
C.0 Overview – Mechanical resistance and stability	8
C.1 Robustness of head-to-bar connection (BWR 1)	9
C.2 Characteristic resistance under static and quasi-static loading (BWR 1)	9
C.3 Characteristic resistance under seismic loading (BWR 1)	9
C.4 Characteristic resistance under fatigue loading (BWR 1).....	10

SPEIFIC PARTS

1. Technical description of the product

HRC100 and 200 Series T-headed bars are steel bars for reinforcement of concrete structures. The bars have devices for mechanical anchorage attached to one or both ends. The anchorage devices (T-heads) are steel plates rigidly connected to the rebar.

For HRC110, HRC120 and HRC150, the T-head plates are connected to the bar by friction welding. The friction welding between the reinforcement bar and the T-head plate complies with EN ISO 15620. For HRC170 a threaded bolt is friction welded to the rebar end. HRC170 are loose T-head plates connected via threads for assembly after installation of the bar.

HRC200 T-heads consist of an anchorage plate and a transition length in one solid part. The HRC200 T-heads can be forged or machined and are friction welded to the rebar end.

The reinforcement bar material complies to EN 10080 and EN 1992-1-1 with 500 MPa characteristic yield strength and ductility class B or C.

Nominal bar diameter is in the range of 12 mm to 40 mm. Nominal anchoring plate thickness is in the range of 10 mm to 25 mm.

A product description is given in Annex A.

2. Specification of the intended use(s) in accordance with the applicable European Assessment Document (hereinafter EAD)

The performances given in Section 3 are only valid if the T-headed bar is used in compliance with the specifications and conditions given in Annex A and B.

The verifications and assessment methods on which this European Technical Assessment is based lead to the assumption of a working life of the T-headed bars of at least 100 years. The indications given on the working life cannot be interpreted as a guarantee given by the producer, but are to be regarded only as a means for choosing the right products in relation to the expected economically reasonable working life of the works.

3. Performance of the product and references to the methods used for its assessment

3.1 Basic Works Requirement 1 (BWR 1) – Mechanical resistance and stability

Table 1: Basic Works Requirement 1 (BWR 1) – Mechanical resistance and stability

No.	Essential characteristic	Product performance	
		Level	Description
1	Robustness of head-to-bar connection	Category B3	See Annex C.1
2	Characteristic resistance under static and quasi-static loading	Category B3	See Annex C.2
3	Characteristic resistance under seismic loading	Category S	See Annex C.3
4	Characteristic resistance under fatigue loading	Category F1	See Annex C.4

3.2 Basic Works Requirement 2 (BWR 2) – Safety in case of fire

Table 2: Basic Works Requirement 2 (BWR 2) – Safety in case of fire

No.	Essential characteristic	Product performance
		Class
5	Reaction to fire Resistance to fire, see Annex B.3	Class A1 , according to EN 13501-1

4. Assessment and verification of constancy of performance (hereinafter AVCP) system applied, with reference to its legal base

In accordance with European Assessment Document EAD No. 160012-01-0301, the applicable European legal act is 96/582/EC. The system to be applied is: 1+

5. Technical details necessary for the implementation of the AVCP system, as provided for in the applicable EAD

Technical details necessary for the implementation of the AVCP system are laid down in the control plan deposited at SINTEF.

Issued in Oslo on 23.12.2024

By

SINTEF



Anne-Jorunn Enstad

Certification manager

ANNEX A – PRODUCT DESCRIPTION

A.1 Dimensions – HRC100 Series

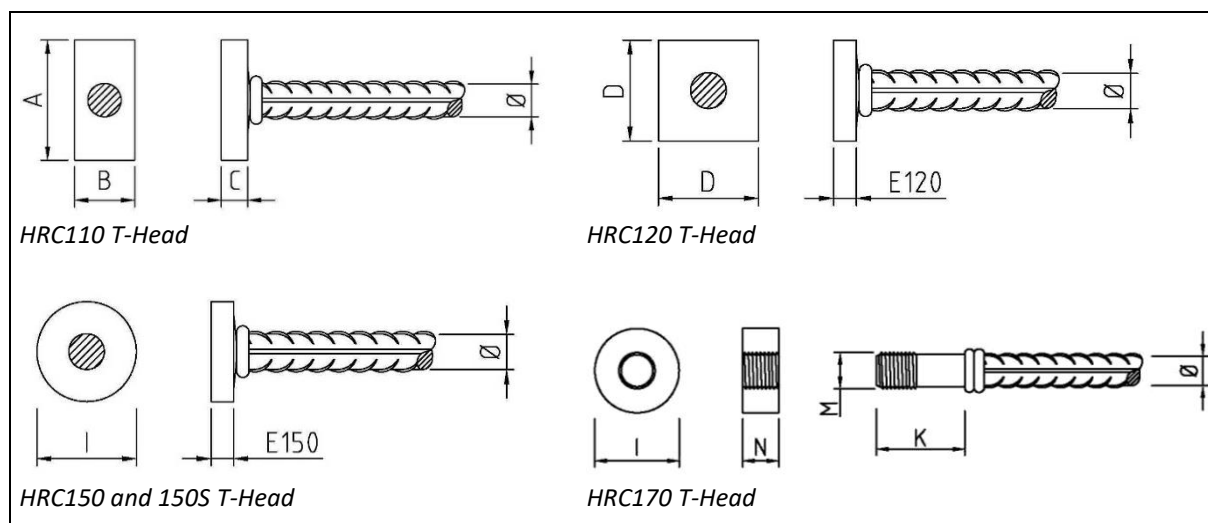

Figure A.1: Dimensions – HRC100 Series

Table A.1: Dimensions – HRC100 Series

Nominal rebar diameter ϕ (mm)	Head dimensions ¹⁾										
	HRC110			HRC120		HRC150/150S		HRC170			
	A (mm)	B (mm)	C (mm)	D (mm)	E120 (mm)	I (mm)	E150 (mm)	I (mm)	K (mm)	M (mm)	N (mm)
12	-	-	-	-	-	38 ²⁾	10 ²⁾	-	-	-	-
16	60	35	14	50	12	50	12	-	-	-	-
20	80	40	18	60	14	65	16	65	70	M24	25
25	100	50	20	70	16	80	20	-	-	-	-
28	-	-	-	80	18	90	20	-	-	-	-
32	120	65	25	90	20	100 ²⁾	25 ²⁾	-	-	-	-
40	-	-	-	110	25	-	-	-	-	-	-

¹⁾ Given head dimensions are to be regarded as minimum sizes. The use of larger T-head plates may be preferable in special situations.

²⁾ HRC150S not in dimension $\phi 12$ and $\phi 28$

A.2 Dimensions – HRC200 Series

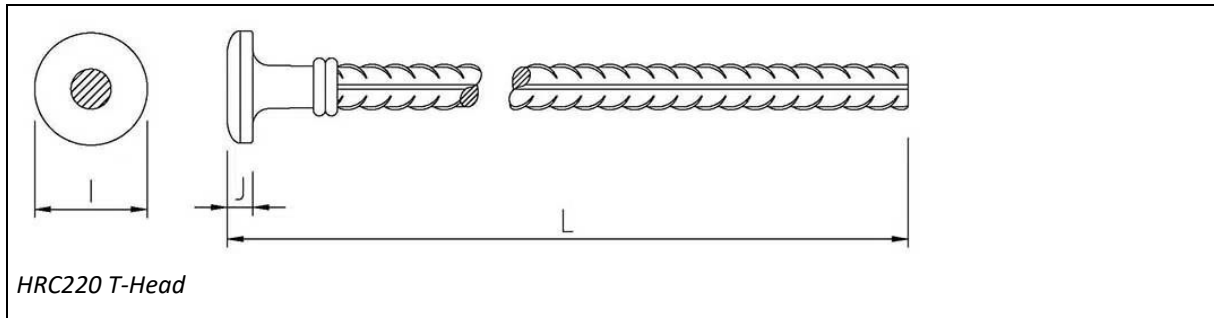

Figure A.2: Dimensions – HRC200 Series

Table A.2: Dimensions – HRC200 Series

Nominal rebar diameter \varnothing (mm)	Head dimensions ¹⁾ HRC220	
	I (mm)	J (mm)
16	50	12
20	60	14
25	70	16
32	90	20

¹⁾ Given head dimensions are to be regarded as minimum sizes. The use of larger T-head plates may be preferable in special situations.

A.3 Materials – HRC100 and 200 Series

Table A.3: Materials – HRC100 and 200 Series

Product designation	Component	Material
All products except HRC150S	Rebar	Reinforcing steel bars of class B or C according to EN 1992-1-1, with $f_{yk} = 500$ MPa.
	Head plate and threaded bolt	1.0590; 1.8901; 1.8907
HRS150S	Rebar	Reinforcing steel bars of class B or C according to EN 1992-1-1, with $f_{yk} = 500$ MPa. Both carbon steel and grade 1.4362 according to applicable national standards.
	Head plate	1.4462

ANNEX B – INTENDED USE

B.1 Specification of intended use

Anchorage of reinforcing steel bars for concrete structures subject to:

- Static and quasi-static loading (HRC110, HRC120, HRC150, HRC150S, HRC170 and HRC220)
- Seismic loading (HRC110, HRC120, HRC150, HRC150S and HRC220)
- High-cycle fatigue loading (HRC110, HRC120, HRC150, HRC150S and HRC220)

Mechanical resistance and stability (category B3, S and F1), see Annex C.

B.2 Concrete

Concrete of minimum strength class C30/37, according to EN 206 and EN 1992-1-1.

B.3 Design

HRC100 and 200 Series T-headed bars are part of the reinforcement for a concrete structure, based on the structural design for the works according to applicable design standards. Necessary bursting and spalling reinforcement, due to partially loaded areas and transverse tension forces shall be considered.

To ensure the resistance to fire, the structure has to be designed and constructed according to the provisions of an appropriate standard for structural fire design.

B.4 Installation

HRC100 and 200 Series T-headed bars shall be installed in accordance with detailed construction documentation, like drawings, models, specifications etc., established for the individual works.

The T-head and the head-to-bar connection shall not be machined or otherwise modified.

Bending of HRC100 and 200 Series T-headed bars shall be carried out such that the start of the bend is at least in a distance of 2 x nominal bar diameter from the head-to-bar connection.

HRC170 T-heads are to be installed by screwing them firmly onto the threaded bolt.

ANNEX C – PRODUCT PERFORMANCE

C.0 Overview – Mechanical resistance and stability

Table C.0: HRC100 and 200 Series – Overview of BWR 1 – Mechanical resistance and stability

Product	Nominal rebar diameter \varnothing (mm)	Product performance (level)		
		1) Robustness of head-to-bar connection 2) Characteristic resistance under static and quasi-static loading Category B3 (see Annex C.1 and C.2)	3) Characteristic resistance under seismic loading Category S (see Annex C.3)	4) Characteristic resistance under fatigue loading Category F1 (see Annex C.4)
HRC110	16	X	X	X
	20	X	X	X
	25	X	X	X
	32	X	X	X
HRC120	16	X	X	X
	20	X	X	X
	25	X	X	X
	28	X	X	X
	32	X	X	X
	40	X	NPA	NPA
HRC150	12	X	NPA	NPA
	16	X	X	X
	20	X	X	X
	25	X	X	X
	28	X	X	X
	32	X	X	X
HRC150S	16	X	X	X
	20	X	X	X
	25	X	X	X
	32	X	X	X
HRC170	20	X	NPA	NPA
HRC220	16	X	X	X
	20	X	X	X
	25	X	X	X
	32	X	X	X

C.1 Robustnes of head-to-bar connection (BWR 1)

Table C.1: HRC100 and 200 Series – Robustnes of head-to-bar connection

Product	Product performance	
	Level	Description
<u>HRC100 Series:</u> HRC110 – ϕ 16 to ϕ 32 (not ϕ 28) HRC120 – ϕ 16 to ϕ 40 HRC150 – ϕ 12 to ϕ 32 HRC150S – ϕ 16 to ϕ 32 (not ϕ 28) HRC170 – ϕ 20 <u>HRC200 Series:</u> HRC220 – ϕ 16 to ϕ 32 (not ϕ 28)	Category B3	For welded heads tested by bend test according to clause 6.3 of ISO 15698-2: No cracks visible in the head, the bar, or the head-to-bar connection.

C.2 Characteristic resistance under static and quasi-static loading (BWR 1)

Table C.2: HRC100 and 200 Series – Characteristic resistance under static and quasi-static loading

Product	Product performance	
	Level	Description
<u>HRC100 Series:</u> HRC110 – ϕ 16 to ϕ 32 (not ϕ 28) HRC120 – ϕ 16 to ϕ 40 HRC150 – ϕ 12 to ϕ 32 HRC150S – ϕ 16 to ϕ 32 (not ϕ 28) HRC170 – ϕ 20 <u>HRC200 Series:</u> HRC220 – ϕ 16 to ϕ 32 (not ϕ 28)	Category B3	Test method: HRC100 series in air; HRC200 in concrete. The capability of head for anchoring corresponds to category B3 according to clause 7.2.2 of ISO 15698-1. For the intended use of headed reinforcing steel bar the minimum concrete characteristic compressive cylinder strength is 30 MPa (minimum strength class C30/37).

C.3 Characteristic resistance under seismic loading (BWR 1)

Table C.3: HRC100 and 200 Series – Characteristic resistance under seismic loading

Product	Product performance	
	Level	Description
<u>HRC100 Series:</u> HRC110 – ϕ 16 to ϕ 32 (not ϕ 28) HRC120 – ϕ 16 to ϕ 32 HRC150 – ϕ 16 to ϕ 32 HRC150S – ϕ 16 to ϕ 32 (not ϕ 28) <u>HRC200 Series:</u> HRC220 – ϕ 16 to ϕ 32 (not ϕ 28)	Category S	Sustained loading program according to clause 7.2.4 of ISO 15698-1, without failure. Stage 4: ductile rupture of the rebar. NPA for: HRC120 – ϕ 40 HRC150 – ϕ 12 HRC170 – ϕ 20

C.4 Characteristic resistance under fatigue loading (BWR 1)

Table C.4a: HRC100 and 200 Series – Characteristic resistance under fatigue loading

Product	Product performance	
	Level	Description
<u>HRC100 Series:</u> HRC110 – ϕ 16 to ϕ 32 (not ϕ 28) HRC120 – ϕ 16 to ϕ 32 HRC150 – ϕ 16 to ϕ 32 HRC150S – ϕ 16 to ϕ 32 (not ϕ 28) <u>HRC200 Series:</u> HRC220 – ϕ 16 to ϕ 32 (not ϕ 28)	Category F1	Assessment method according to clause 2.2.4 in EAD 160012-01-0301. - Sustained loading program according to clause 7.2.3 in ISO 15698-1, with failure in affected zone. - The number of cycles of rebar at stress ranges and maximum number of cycles and stress ranges of headed bar tested in one series are given in Table C.4b. NPA for: HRC120 – ϕ 40 HRC150 – ϕ 12 HRC170 – ϕ 20

Table C.4b: HRC100 and 200 Series – Characteristic resistance under fatigue loading – Test results

Product	Nominal rebar diameter (mm)	Upper stress level ¹⁾	Lower stress level ²⁾	Stress range ³⁾	Number of cycles N (-)
		σ_{max} (MPa)	σ_{min} (MPa)	$2\sigma_a$ (MPa)	
<u>HRC100 Series:</u> HRC120	16	300	50	250	148.752
		300	138	162	359.107
	25	300	50	250	26.464
		300	138	162	92.914
	32	300	50	250	28.276
		300	138	162	128.588
<u>HRC200 Series:</u> HRC220	16	300	50	250	263.046
		300	138	162	1.639.141
	25	300	50	250	363.506
		300	138	162	947.502
	32	300	50	250	252.462
		300	138	162	672.722

¹⁾ Upper stress level: $\sigma_{max} = 0,6 \cdot f_{yk} = 300 \text{ MPa}$

²⁾ Lower stress level: $\sigma_{min,low} = 50 \text{ MPa}$

$$\sigma_{min,high} = 0,276 \cdot f_{yk} = 138 \text{ MPa}$$

³⁾ High stress range: $2\sigma_{a,high} = 0,5 \cdot f_{yk} = 250 \text{ MPa} (= \sigma_{max} - \sigma_{min,low})$

Low stress range: $2\sigma_{a,low} = 0,324 \cdot f_{yk} = 162 \text{ MPa} (= \sigma_{max} - \sigma_{min,high})$